

# AS-750A/B PARTS

## Set Parts List

#1 Stand Leg	2 pcs	#7 Hole Plate	2 pcs
#2 Nut Sleeve	4 Pcs	#8 Nut Plate	2 Pcs
#3 Button Bolt	8 Pcs	#9 Push Bolt	2 Pcs
#4 Washer	8 Pcs		
#5 Shelf	1 Pc		
#6 Wrench	1 Pc		

## ASSEMBLY INSTRUCTION

**CAUTION:** ONLY SET UP THE STAND LEGS ON FLAT, LEVEL, STABLE, HARD SURFACE MOUNT OR FLOOR. SCREENS & STANDS ARE HEAVY, DO NOT USE IN PLACES WHERE PHYSICAL COLLISION OR FORCIBLE TIPPING MAY OCCUR. IF THERE IS THE POTENTIAL OF FORCED TIPPING OR COLLISION OR HIGH WIND, FIX STAND LEGS TO MOUNTING SURFACE BY MECHANICAL MEANS SUCH AS BRACKETS OR INSERTION CHANNEL. USE PROPER CARE AND CONSIDERATION BEFORE SETTING UP.

- 1** Put washers on button bolt, pass through stand leg and tighten snugly into nut sleeve with wrench. Repeat procedure for all four nut sleeves.

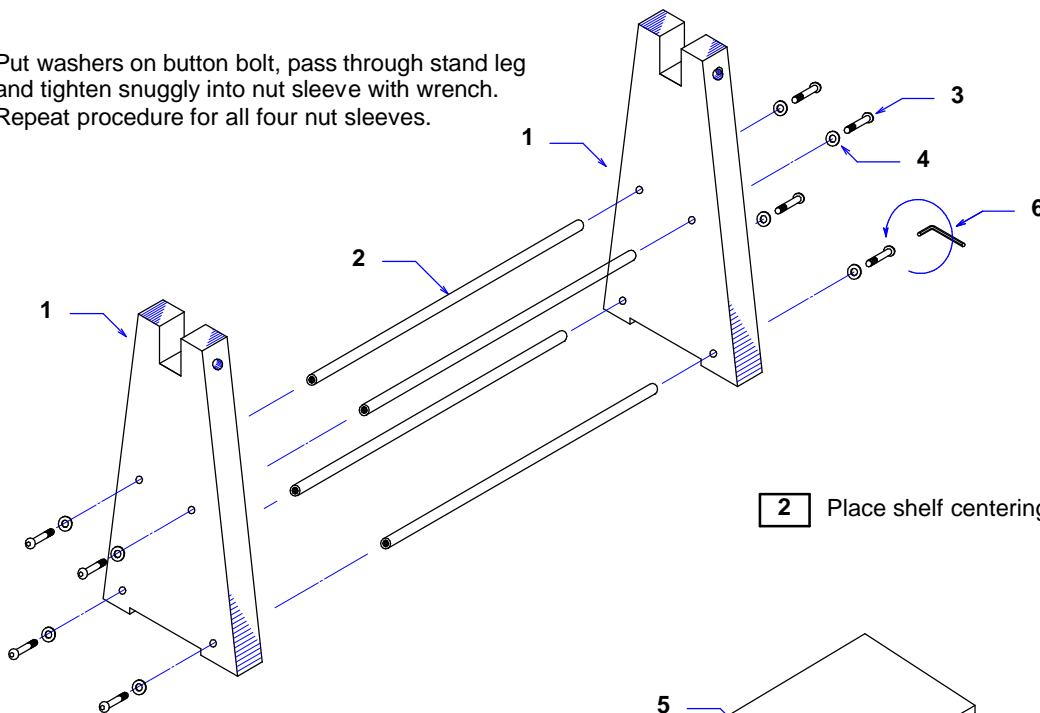

- 2** Place shelf centering on bottom two nut sleeves.

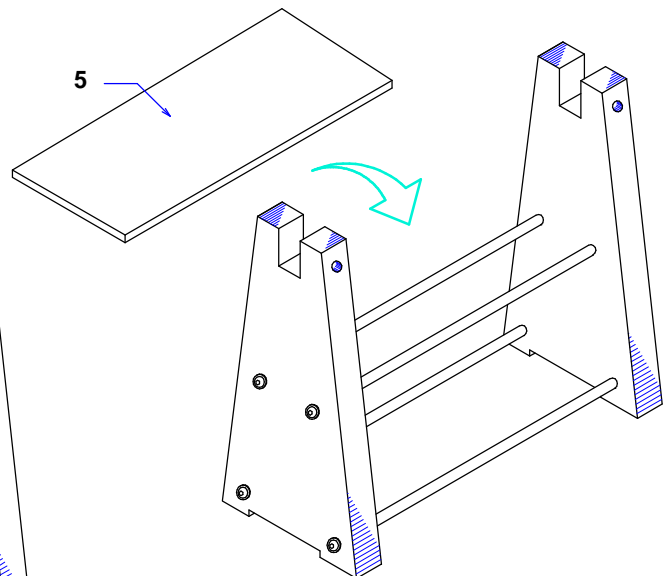

- 3** Place on flat, hard level surface where there is no danger of shifting, collision or tipping over. CAUTION: Screens & Stands are Heavy.

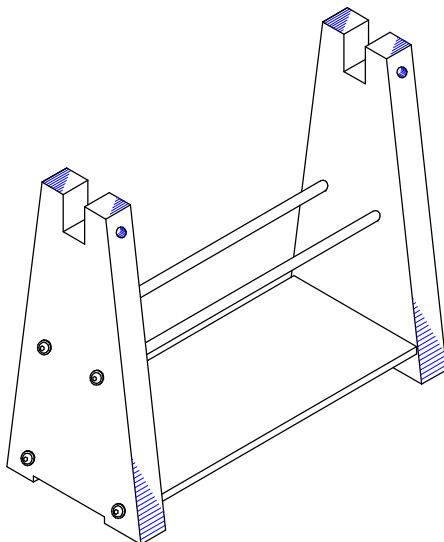

4 Carefully peel back about 4 inches of the protect film from the screen flanges before setting the Screen into the stand channel. Then using proper amount of persons (no less than 2) carefully set and center the Screen into the top stand channels. Have one person hold Screen in place firmly against the front rubber while the other prepares to install the fixing hardware. Be careful not to get fingers jammed between Screen and Stand.

**CAUTION:** Holes located in the flanges of the Screen are for use with separate Suspension Kit assembly. These holes are not used for this STAND KIT. Do NOT try to thread button bolts or push bolt into holes, doing so will cause damage.

**CAUTION:** These Holes are NOT for use with Stand. DO NOT insert/thread the push bolts into this holes!

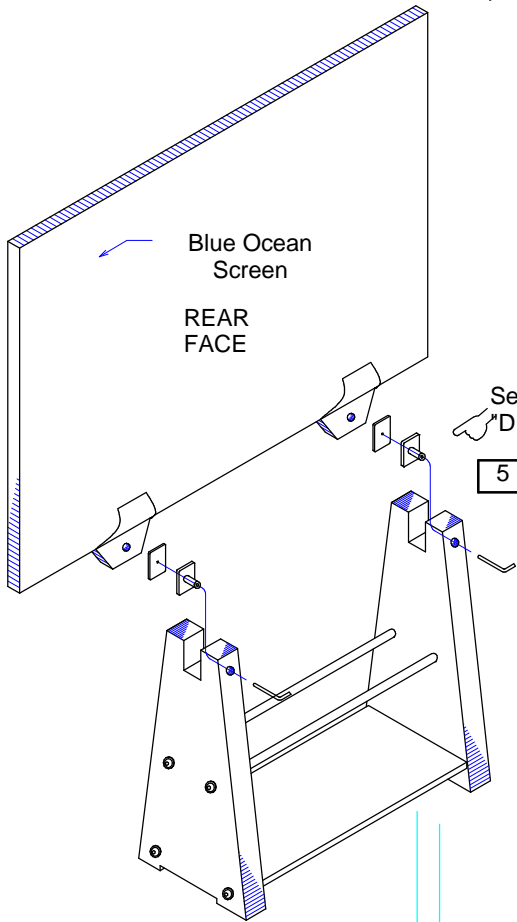
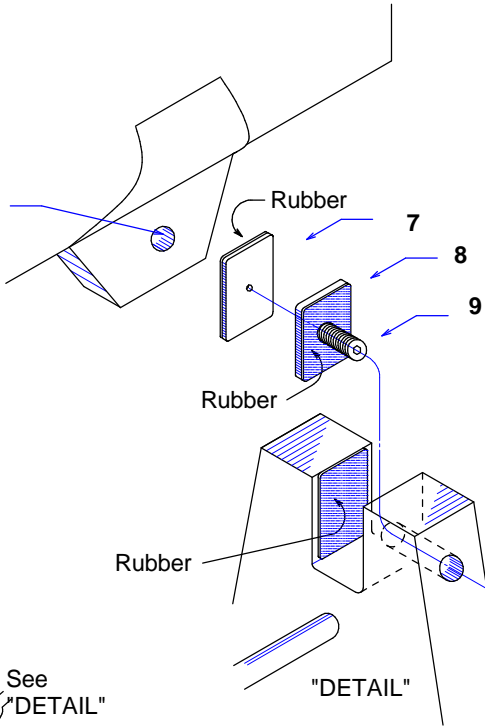

5 From the side of the Stand and NOT the top, insert the nut plate and hole plate between the Screen and Stand. This will help prevent scratching of Screen. Now align the hole of the Stand and nut plate. Insert the push bolt and screw into the nut plate. Tighten until the Screen is firmly compressing the front rubber pad. Tighten firmly so that the Screen is secure.

Warning: do not use other tools, use only the tools included. Over torquing with larger tools can damage Screen & hardware.

**!** Insert Plates from Side and not Top, to prevent accidental scratching of Screen. Be careful not to get fingers pinched!

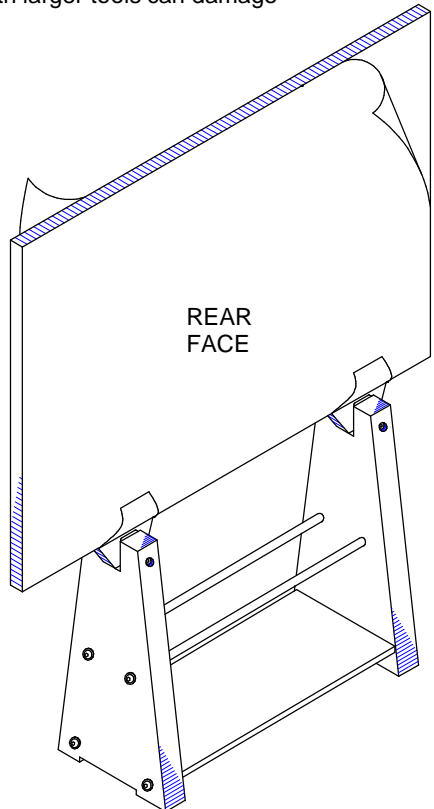
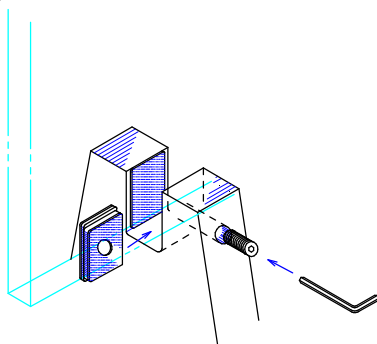

6 Carefully remove the remaining protection film. Remember to store for future packing or shipping. Do not dispose of!

7 Periodically check and tighten push bolt for Safety and make sure assembly is tight and secure.